



Project:	_____
Location:	_____
Item #:	_____
Quantity:	_____

Big Top Salad/Sandwich Refrigerators

One Section Model with Door **VUR-3-BT**

Door, top and interior floor of stainless steel.
Aluminum ends and interior.



Standard Features:

- Stainless Steel Door, Top and Interior Bottom Construction Provides Durable Lasting Finish
- Durable Aluminum Interior Sides and Rear for Easy Cleaning
- Models are Front-Breathing and Recessible to Enable Zero Clearance Placement or in Limited Access Areas
- Food Pans are Recessed into an Insulated 2" Top which Surrounds Pans With an Insulated Airflow to Maintain Consistent Temperature
- Holds Food Safely and Assures Fresher Food
- Exclusive Design Accepts 4" and 6" Pans Which Maximize Airflow and Maintain Temperature
- A Complete Set of 4" Deep Plastic Pans are Included
- Interior Thermometer Consistently Monitors Temperature
- Spacious Design With 10" Cutting Board Provides Maximum Work Surface and Condiment Storage Capacity
- Removable Stainless Steel Insulated Telescoping Lid Offers Easy Cleaning
- Self-Closing Door With Replaceable One-Piece Magnetic Gasket Maintains Positive Seal
- Horizontal Recessed Heavy-Duty Handles Provide Quicker, Easier Access to Cabinets
- Heavy-Duty, Epoxy Coated Steel Shelves Accept Heavy Loads and Offer Easy Clean-up

- Adjustable Shelves Provide Storage Flexibility
- Energy Saving, High Density, Polyurethane Foam Insulation Promotes Cold Retention
- Anti-Corrosion Coated Evaporator Coil Assures Lasting Performance
- Automatic Condensation Evaporation System Eliminates the Need for a Floor Drain
- Balanced, Energy Efficient Refrigeration System
- Environmentally Friendly R-134a Refrigerant
- Plugs into Standard 115 V Outlets - Cord and Plug Attached for Easy Installation
- 5" Heavy-Duty Swivel Casters with Brakes Provide Mobility
- Completely Finished and Enclosed Cabinet Back Allows for Placement in the Front or Back of the House
- Meets Tough NSF Standard 7, 41° F

Optional Features and Accessories:

- 3" Heavy-Duty Swivel Casters with Brakes
- 6" Adjustable Stainless Steel Legs
- Single and Double Overshelf
- Stainless Steel Back
- Door Mounted Dial Thermometer
- Cylinder Locks

Approvals:



Victory Refrigeration specification sheets are available online at www.victory-refrig.com.

CHARACTERISTICS	VUR-3-BT
Width, Overall	27 1/2
Depth, Overall	34
Height, Overall	46
Height, Work Area	36
Capacity Net (cubic feet)	6
No. of Full Doors	1
No. of Shelves	2
No of 1/5 Size Pans	12
Cabinet Voltage	115/60/1
Condensing Unit Voltage	115/60/1
Condensing Unit Size (HP)	1/5
Total Amperes	4.8

Crated dim. & wts.	Ht.	Width	Depth	Lbs.
VUR-3-BT	48 1/2	33	39 1/2	230

Dimensional tolerance $\pm 1/4"$ Metric dimensions (MM)

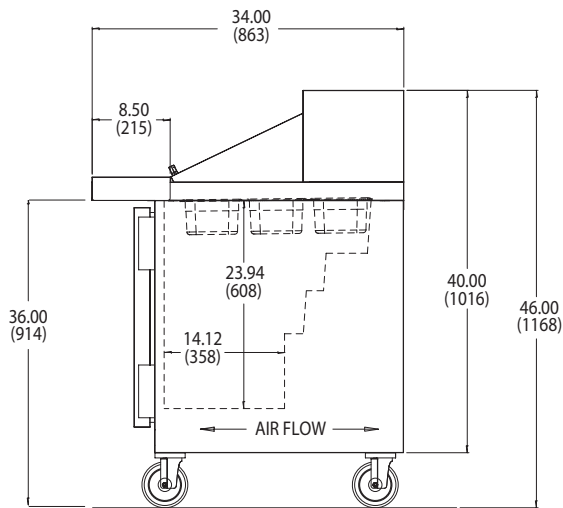

SIDE VIEW

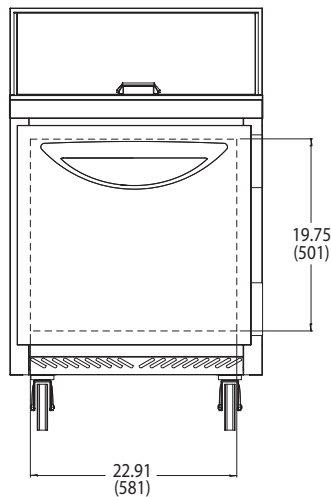

FRONT VIEW

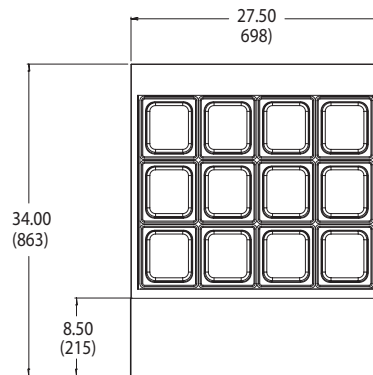

TOP VIEW

NOTE: If cabinet is located directly against wall and/or under low ceiling, a minimum clearance of 2" is required.

We reserve the right to change specifications and product design without notice. Such revisions do not entitle the buyer to corresponding changes, improvements, additions or replacements for previously purchased equipment.

Continuous product development may necessitate specification changes and design without notice.



Victory participates in the KCL CADalog, the most current source of CAD symbols for foodservice designers worldwide. Symbols include standard equipment in plan, side, front and 3-D views, layered for FEDA/FCSI recommended guidelines.